

# PD43-03 Mid-Infrared Photodiodes

## Description

Photodiodes PD43-03 are fabricated from narrow band-gap InAsSb-based heterostructures lattice matched to InAs substrate, and are designed for detection of light signals in Mid-Infrared spectral range with cut-off wavelength around 4.8  $\mu\text{m}$ .

## Features

- Diameter of photosensitive area: 0.3 mm
- Fast Response: <50 ns
- Package: TO-18

## Applications

- Industrial Process Control
- Sensor development
- Medical diagnostics

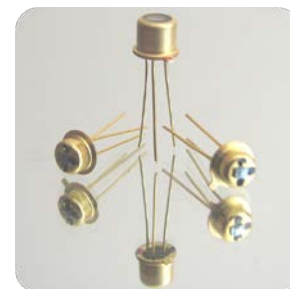

## Specification

### Recommended modes of PD operation

We recommend using photovoltaic mode, when PD is used under no reverse bias.

PD used as a current source (photovoltaic mode)	PD used in a photoconductive mode (under reverse bias)

### Device Parameters

Device Parameters	Symbol	Value	Units
Sensitive area diameter	d	0.3	mm
Storage temperature	$T_{\text{stg}}$	-200 ~ +70	$^{\circ}\text{C}$
Operating temperature	$T_{\text{opr}}$	-200 ~ +60	$^{\circ}\text{C}$
Reverse voltage	$V_r$	-1	V

### Optical and Electrical Characteristics

Photodiode Parameters	Conditions	Symbol	Value	Units
Cut-off wavelength	T=300 K	$\lambda_{cut}$	4.8	$\mu\text{m}$
Max. sensitivity wavelength (>90%)	T=300 K	$\lambda_p$	3.6 — 4.1	$\mu\text{m}$
Dark current	T=300 K, $V_r=-1$ V	$I_d$	4.0— 10	$\mu\text{A}$
Shunt resistance	T=300 K, $V_r=-10$ mV	$R_{sh}$	9 — 15	k $\Omega$
Capacitance	T=300 K, $\lambda=\lambda_p$	C	2000	pF
Sensitivity	T=300 K, $\lambda=\lambda_p$	S	0.7-0.9	A/W
Detectivity	T=300 K, $\lambda=\lambda_p$	$D^*$	(5-8)*10 <sup>8</sup>	cm.Hz <sup>1/2</sup> .W <sup>-1</sup>

### Typical Characteristic Curves

Spectral response (typical)

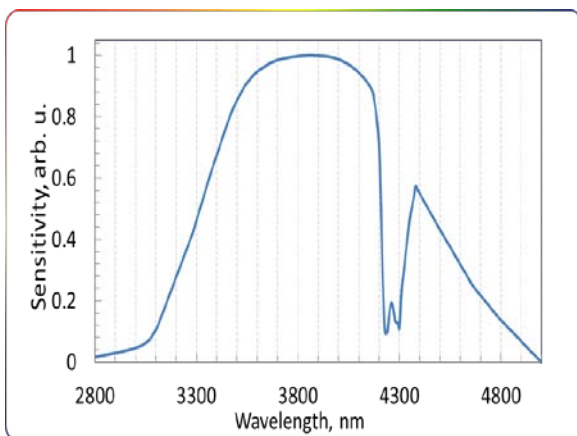

Temperature shift of spectral response

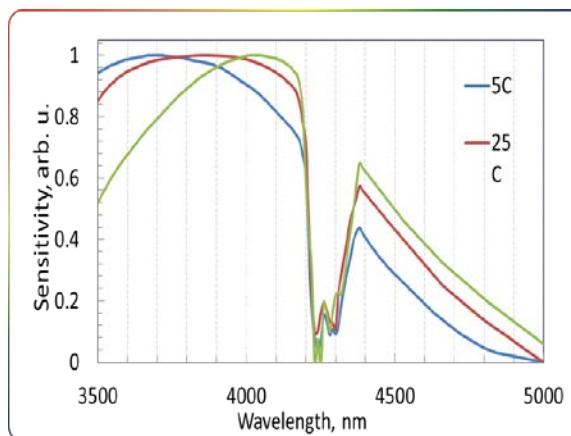

Dark current temperature dependence

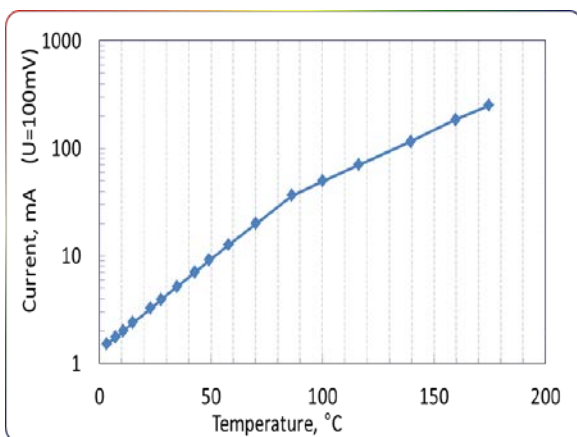

Resistance-temperature dependence

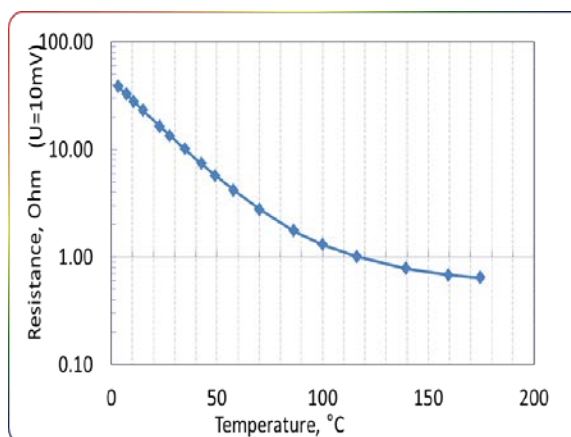

## TO18 Package with a cap without a glass window

Dimension Drawing (units: mm)

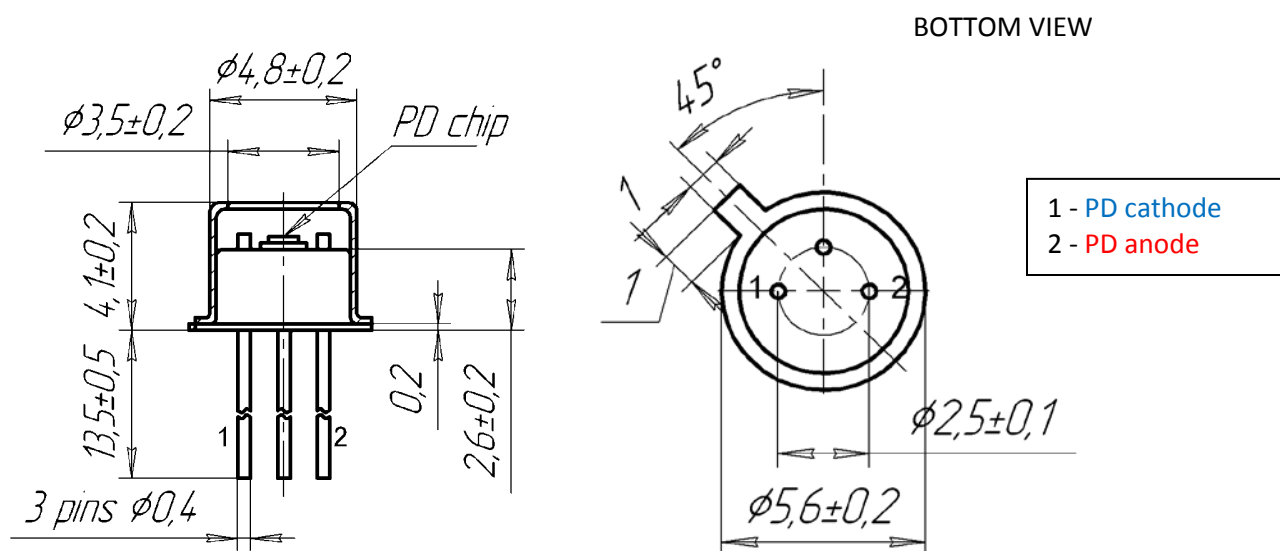

## Precautions

Photodiodes are polarity sensitive. Please note the anode of PD is marked with a RED dot. Check all polarity connections before using the device. Please do not connect the PD to the multimeter.

The MID-IR photodiodes are ESD (electro static discharge) sensitive and should be handled with the proper ESD protection environment.